

ELECTRIC RIDERS

Tri-Wheel Multi-Tire Lift Trucks Electric 36 or 48 Volt

TMX12	2,500 lbs 1250 kg
TMX15S	3,000 lbs 1500 kg
TMX15	3,000 lbs 1500 kg
TMX17	3,500 lbs 1750 kg
TMX20	4,000 lbs 1815 kg
TMX25	5,000 lbs 2270 kg



TMX12/15/15S 17/20/25



CLARK[®]
BUILT TO LAST.[®]

For corresponding data see Specification Chart.

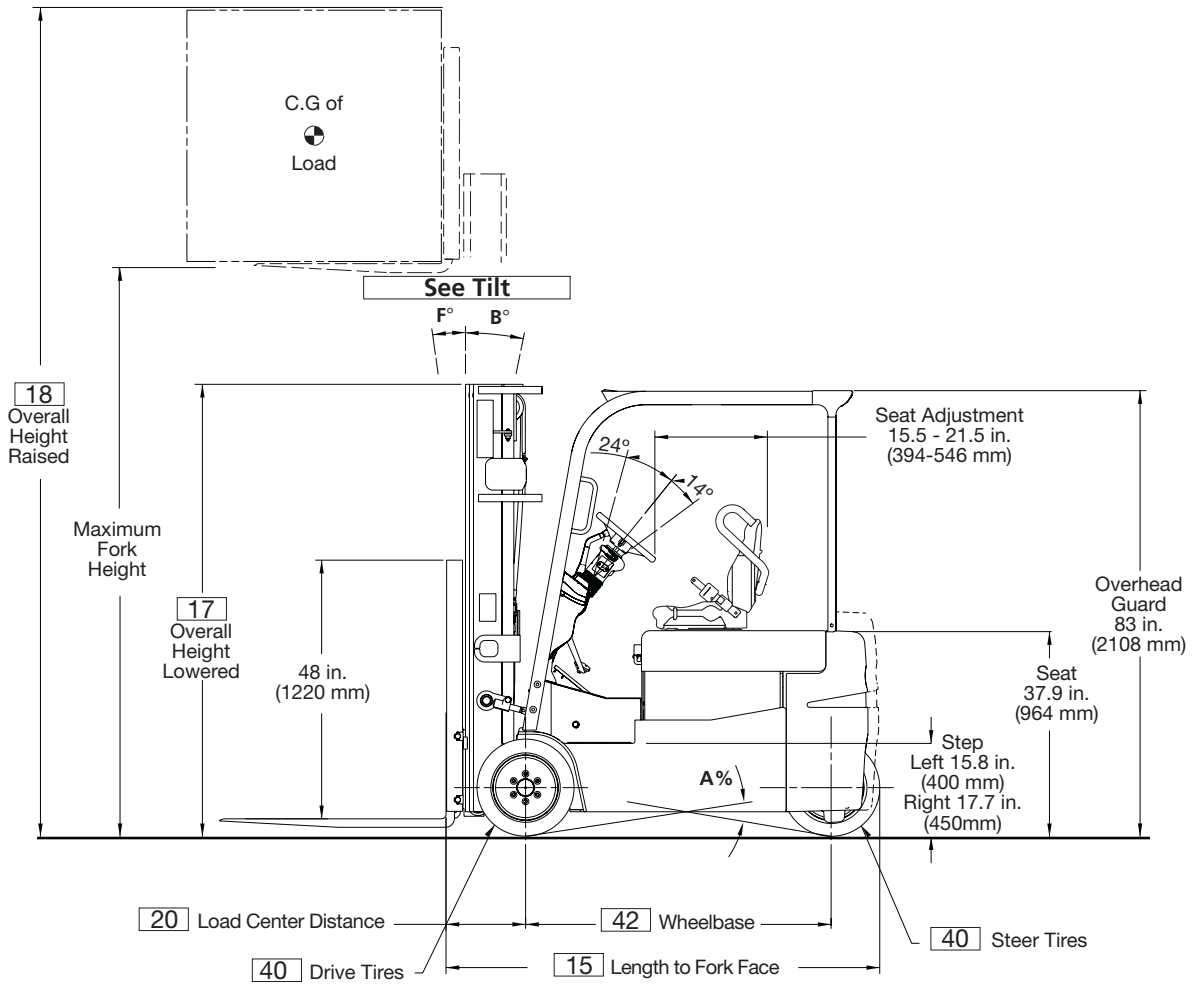

TMX12/15/15S/17/20/25

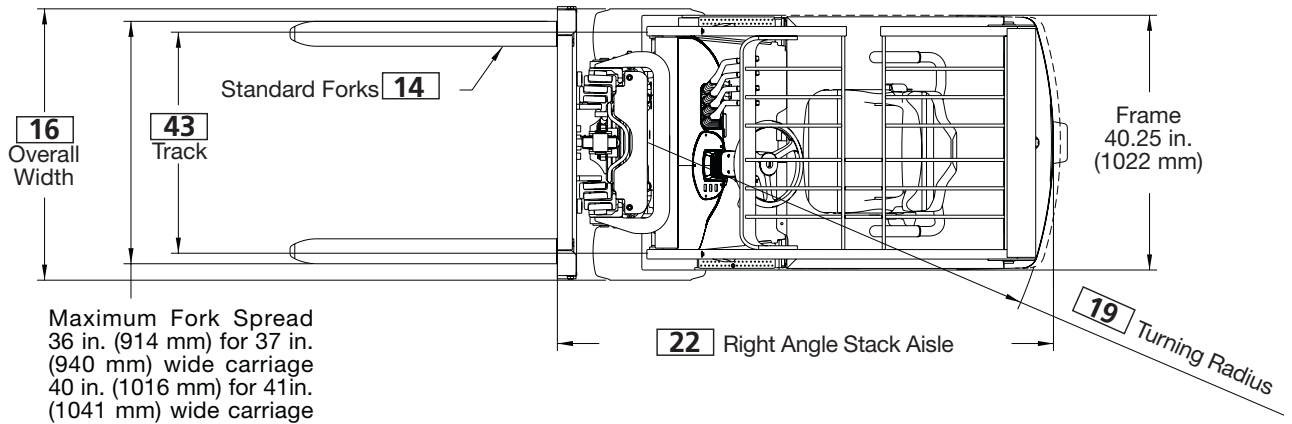

Upright Table

Maximum Fork Height		Overall Height Lowered		Free Lift**	
in	mm	in	mm	in	mm

TMX 12/15S/15/17/20 Standard

100	2540	72.5	1842	4.3	109
110	2794	77.5	1969	4.3	109
• 121	3073	83	2108	4.3	109
129	3277	87	2210	4.3	109
143	3632	94	2388	4.3	109

Hi-Lo

115	2921	77.5	1969	53	1346
• 126	3200	83	2108	59	1500
150	3810	95.5	2425	71	1803

Triple Stage

156	3971	72.5	1840	48	1219
171	4346	77.5	1965	53	1355
• 188	4781	83	2110	59	1500
204	5184	89	2260	65	1650
219	5565	95.5	2420	71	1803
237	6017	103	2609	78	2004

Quad†

222.5	5652	78.5	1994	53	1346
• 240.5	6109	83	2108	57	1448
258.5	6566	89	2261	63	1600
270.5	6871	93.5	2375	70	1778

TMX 25 Standard

Same as TMX 12-20 listed above

Hi-Lo

114	2896	77.5	1969	53	1346
• 125	3175	83	2108	59	1499
149	3785	95.5	2426	71	1803

Triple Stage

155	3947	72.5	1840	49	1245
170	4322	77	1965	54	1372
• 187	4757	83	2110	59	1500
203	5160	89	2260	65.5	1664
218	5541	95.5	2425	71	1803
236	5993	103	2609	79	2004

Quad†

222.5	5652	78.5	1994	53	1346
• 240.5	6109	83	2108	57	1448
258.5	6566	89	2261	63	1600
270.5	6871	93.5	2375	70	1778

- Indicates preferred standard sizes. For overall height raised with load backrest, add 48 in. (1220 mm) to maximum fork height. Other uprights available, contact a Clark representative.

** All free lift dimensions shown without standard 48 in. (1220 mm) high load backrest.

† Length to face of fork, RAS and turning radius increase 4 in. with quad installation.

Tilt Specifications*

Upright MFH(in / mm)	Tilt -B°/ F°
thru 151 (3835 mm)	8°/ 6°
152 (3860 mm) thru 240.5 (6109 mm)	5°/ 3°
241 (6121 mm) and over	3°/ 0°

*Standard tilt with MFH's noted. Contact Clark representative for information on optional tilt.

Grade Clearance

Model	A%
TMX 12/15S (13.75 BC)	35.6
TMX 15/17/20/25 (20.5 BC)	31.2
TMX 15/17/20/25 (25.22 BC)	28.6

Battery Compartment Dimensions

Width (W)		Length (L)		Height (H)	
in	mm	in	mm	in	mm

TMX 12/15S

38.8	986	13.75	349	31.0	787
------	-----	-------	-----	------	-----

TMX 15/17/20/25

38.8	986	20.5	521	31.0	787
38.8	986	25.0*	635	31.0	787

*Optional

Battery Termination: A-18

Standard Features

- Overhead guard
- 48 in. (1220 mm) load backrest
- Electric horn
- Single auxiliary hydraulic valve
- CLARK green paint w/non-glare black trim
- High visibility capacity plate/instructions/warning labels
- Operator manual attached to back of seat

Available Equipment

- Dual steer tires
- Cold storage protection
- UL type EE construction
- Overhead guard for drive-in type rack
- Unitrol™, foot operated directional control
- Warning lights and audible alarms
- Mirrors
- 48 volt option

Notes

Performance may vary +5% and -10% due to motor and system efficiency tolerance. The performance shown represents nominal values which may be obtained under typical operating conditions of a machine.

Clark products and specifications are subject to change without notice.

© Clark Material Handling Company 2004.

ANSI/ASME and Insurance Classification

Standard truck meets all applicable mandatory requirements of ASME-B56.1 Safety Standard for Powered Industrial Trucks at time of manufacture and Underwriters Laboratories requirements as to fire and electrical shock hazard only for "E" classification. For further information contact a Clark representative.

For Your Safety

Before operating a lift truck, an operator must:

- Be trained and authorized
- Read and understand the operator's manual
- Not operate a faulty lift truck
- Not repair a lift truck unless trained and authorized
- Have the overhead guard and load backrest extension in place

During operation, a lift truck operator must:

- Wear a seat belt
- Keep entire body inside truck cab
- Never carry passengers or lift people
- Keep truck away from people and obstructions
- Travel with lift mechanism as low as possible and tilted back

To park a lift truck, an operator must:

- Completely lower forks or attachments
- Shift into neutral
- Turn key off
- Set parking brake

Contact your Clark dealer for operator training information.

S P E C I F I C A T I O N S

General Information	1	Manufacturer		Clark	Clark	
	2	Model	Manufacturer's Designation	TMX 12	TMX 15S	
	3	Load Capacity	lbs(kg)	2500 (1250)	3000 (1500)	
	4	Load Center	Fork Face to Load CG	in(mm)	24 (500)	24 (500)
	5	Power Unit	Electric	36 volt 48 volt	36 volt 48 volt	
	6	Operator Type		Rider Counterbalanced	Rider Counterbalanced	
	7	Tire Type	Multi-Tire	Cushion Pneumatic	Cushion Pneumatic	
	8	Wheels (x=driven)	Front/Rear	2x / 1	2x / 1	
Basic Dimensions ²	9	Upright ¹	Maximum Fork Height, Full Capacity	in(mm)	156 (3971)	156 (3971)
	10		Lift Height (preferred Triple Stage)	in(mm)	188 (4781)	188 (4781)
	11		Free Lift, Triple Stage	in(mm)	59 (1500)	59 (1500)
	13	Upright Tilt	Back/Forward, TSU upright	degrees	5 / 3	5 / 3
	14	Forks	Std. Fork Size (T x W x L)	in(mm)	1.5 x 4 x 42 (40 x 100 x 1067)	1.5 x 4 x 42 (40 x 100 x 1067)
	15	Overall Dimensions	Length to Fork Face	in(mm)	69.5 (1765)	69.5 (1765)
	16		Width	in(mm)	40.25 (1022)	40.25 (1022)
	17		Height, Upright Lowered (188 TSU)	in(mm)	83 (2108)	83 (2108)
	18		Height, Upright Extended (188 TSU)	in(mm)	236 (5994)	236 (5994)
	19	Turning Radius		in(mm)	53.4 (1356)	53.4 (1356)
	20	Load Center Distance	Center of Drive Axle to Fork Face	in(mm)	14.4 (366)	14.4 (366)
	21					
	22	Right Angle Stack Aisle	Add Load Length and Clearance	in(mm)	67.8 (1722)	67.8 (1722)
	Performance ²	23	Stability	According to ANSI	Yes	Yes
24		Speeds	Travel Speed, Max w/ Load	mph(kph)	9.3 (15) 9.3 (15)	9.3 (15) 9.3 (15)
25			Travel Speed, Max w/o Load	mph(kph)	9.3 (15) 9.3 (15)	9.3 (15) 9.3 (15)
26		Lift/Lower Speeds, Loaded	Triple Stage	fpm(ms)	73(.37)/86(.44) 83(.42)/86(.43)	69(.35)/86(.43) 81(.41)/86(.43)
27		Lift/Lower Speeds, Empty	Triple Stage	fpm(ms)	104(.53)/77(.39) 118(.60)/77(.39)	104(.53)/77(.39) 118(.60)/77(.39)
28		Drawbar Pull (S2-60 min.)	Loaded ⁵	lbs(N)	1790(7960) 1630(7250)	1790(7960) 1630(7250)
29		Drawbar Pull (S2-5 min.)	Loaded ⁵	lbs(N)	4325(19235) 4325(19235)	4325(19235) 4325(19235)
30		Gradeability @ 1mph	Loaded ⁶	%	46 46	40 40
34			Unloaded ⁶	%	22 22	20 20
Weights ²		35	Service Weight	TSU Min Battery Weight (No Load)	lbs(kg)	7249 (3288)
	36	Axle Loading	With Load, Front ⁷	lbs(kg)	8701 (4043)	9594 (4467)
	37		With Load, Rear ⁷	lbs(kg)	1048 (496)	1314 (620)
	38		W/O Load, Front	lbs(kg)	4114 (1866)	4090 (1855)
	39		W/O Load, Rear	lbs(kg)	3135 (1422)	3818 (1732)
Chassis	40	Tires (Standard)	Number, Front/Rear		2 / 1	2 / 1
			Size, Front	in	18x7x12.12 18x7-8 16PR ⁴	18x7x12.12 18x7-8 16PR ⁴
			Size, Rear	in	18x7x12.12 18x7-8 16PR ⁴	18x7x12.12 5.00-8/4.50 ^{8,4}
	41		Size, Rear Dual Steer	in	15x5x11.25 15x4.5-8 ³	15x5x11.25 15x4.5x8 ³
	42	Wheelbase		in(mm)	46.0 (1168)	46.0 (1168)
	43	Track	Front, Cushion	in(mm)	33.3 (846)	33.3 (846)
	44		Front, Pneumatic	in(mm)	33.9 (861)	33.9 (861)
	45	Ground Clearance	Min w/Load	in(mm)	3.25 (83)	3.25 (83)
	46		At Center of Wheelbase	in(mm)	4.1 (104)	4.1 (104)
	47	Service Brake	Type		Disc	Disc
	Parking Brake	Type		Hand lever actuated	Hand lever actuated	
48	Steering	Type		Hydrostatic	Hydrostatic	
Drive Line		Battery	Type		Lead-acid	Lead-acid
			Max Capacity (6 hr. Rate)	kWh	27.0	27.0
	49		Weight, Min	lbs(kg)	1650 (749)	1650 (749)
	50	Motors, Controls	Drive Motor, Diameter	in(mm)	7.9 (200)	7.9 (200)
	51		Hydraulic Motor Diameter	in(mm)	6.7 (170)	6.7 (170)
	52		Drive Motor Control		Inverter	Inverter
	53		Speed Control		Solid state	Solid state
	54		Hydraulic Motor Control		Inverter	Inverter
	55					
	56					
	57					
		Hydraulic Pressure	For Attachments	psi/bar	Adjustable	Adjustable

Notes:
1 See Upright Table. Contact Clark Representative for additional lift heights.
2 Specifications are given with the upright noted in line 10.
3 Solid pneumatic only.
4 Reduces capacity, contact factory.

General Information	1	Manufacturer		Clark	Clark	
	2	Model	Manufacturer's Designation	TMX 15	TMX 17	
	3	Load Capacity	lbs(kg)	3000 (1500)	3500 (1750)	
	4	Load Center	Fork Face to Load CG	in(mm)	24 (500)	24 (500)
	5	Power Unit	Electric	36 volt 48 volt	36 volt 48 volt	
	6	Operator Type		Rider Counterbalanced	Rider Counterbalanced	
	7	Tire Type	Multi-Tire	Cushion Pneumatic	Cushion Pneumatic	
	8	Wheels (x=driven)	Front/Rear	2x / 1	2x / 1	
Basic Dimensions²	9	Upright ¹	Maximum Fork Height, Full Capacity	in(mm)	156 (3971)	156 (3971)
	10		Lift Height (preferred Triple Stage)	in(mm)	188 (4781)	188 (4781)
	11		Free Lift, Triple Stage	in(mm)	59 (1500)	59 (1500)
	13	Upright Tilt	Back/Forward, TSU upright	degrees	5 / 3	5 / 3
	14	Forks	Std. Fork Size (T x W x L)	in(mm)	1.5 x 4 x 42 (40 x 100 x 1067)	1.5 x 4 x 42 (40 x 100 x 1067)
	15	Overall Dimensions	Length to Fork Face	in(mm)	76.1 (1933)	76.1 (1933)
	16		Width	in(mm)	40.25 (1022)	40.25 (1022)
	17		Height, Upright Lowered (188 TSU)	in(mm)	83 (2108)	83 (2108)
	18		Height, Upright Extended (188 TSU)	in(mm)	236 (5994)	236 (5994)
	19	Turning Radius		in(mm)	59.8 (1519)	59.8 (1519)
	20	Load Center Distance	Center of Drive Axle to Fork Face	in(mm)	14.4 (366)	14.4 (366)
	21					
	22	Right Angle Stack Aisle	Add Load Length and Clearance	in(mm)	74.2 (1885)	74.2 (1885)
	Performance²	23	Stability	According to ANSI	Yes	Yes
24		Speeds	Travel Speed, Max w/ Load	mph(kph)	9.3 (15.0) 9.3 (15.0)	9.3 (15.0) 9.3 (15.0)
25			Travel Speed, Max w/o Load	mph(kph)	9.3 (15.0) 9.3 (15.0)	9.3 (15.0) 9.3 (15.0)
26		Lift/Lower Speeds, Loaded	Triple Stage	fpm(ms)	69(.35)/86(.43) 81(.41)/86(.43)	65(.33)/86(.43) 75(.38)/86(.43)
27		Lift/Lower Speeds, Empty	Triple Stage	fpm(ms)	104(.53)/77(.39) 118(.60)/77(.39)	104(.53)/77(.39) 118(.60)/77(.39)
28		Drawbar Pull (S2-60 min.)	Loaded ⁵	lbs(N)	1790(7960) 1630(7250)	1790(7960) 1630(7250)
29		Drawbar Pull (S2-5 min.)	Loaded ⁵	lbs(N)	4325(19235) 4325(19235)	4325(19235) 4325(19235)
30		Gradeability @ 1mph	Loaded ⁶	%	40 40	36 36
			Unloaded ⁶	%	23 23	21 21
Weights²		34	Service Weight	TSU Min Battery Weight (No Load)	lbs(kg)	7921 (3593)
	35	Axle Loading	With Load, Front ⁷	lbs(kg)	9796 (4561)	10819 (4997)
	36		With Load, Rear ⁷	lbs(kg)	1125 (532)	986 (521)
	37		W/O Load, Front	lbs(kg)	4610 (2091)	4769 (2163)
	38		W/O Load, Rear	lbs(kg)	3311 (1502)	3536 (1604)
	Chassis	39	Tires (Standard)	Number, Front/Rear		2 / 1
40			Size, Front	in	18x7x12.12 18x7-8 16PR ⁴	18x8x12.12 18x9-8 16PR ⁴
			Size, Rear	in	18x7x12.12 18x7-8 16PR ⁴	18x7x12.12 NA
			Size, Rear Dual Steer	in	15x5x11.25 15x4.5-8 ³	15x5x11.25 15x4.5x8 ³
41		Wheelbase		in(mm)	52.7 (1339)	52.7 (1339)
42		Track	Front, Cushion	in(mm)	33.3 (846)	32.3 (820)
43			Front, Pneumatic	in(mm)	33.9 (861)	33.6 (853)
44		Ground Clearance	Min w/Load	in(mm)	3.25 (83)	3.25 (83)
45			At Center of Wheelbase	in(mm)	4.1 (104)	4.1 (104)
46		Service Brake	Type		Disc	Disc
47		Parking Brake	Type		Hand lever actuated	Hand lever actuated
	Steering	Type		Hydrostatic	Hydrostatic	
Drive Line	48	Battery	Type		Lead-acid	Lead-acid
			Max Capacity (6 hr. Rate)	kWh	43.0	43.0
			Weight, Min	lbs(kg)	2590 (1176)	2590 (1176)
	49	Motors, Controls	Drive Motor, Diameter	in(mm)	7.9 (200)	7.9 (200)
	50		Hydraulic Motor Diameter	in(mm)	6.7 (170)	6.7 (170)
	51		Drive Motor Control		Inverter	Inverter
	52		Speed Control		Solid state	Solid state
	53		Hydraulic Motor Control		Inverter	Inverter
	54					
	55					
56						
57	Hydraulic Pressure	For Attachments	psi/bar	Adjustable	Adjustable	

Notes: 5 Drawbar pull and Gradeability ratings are calculated values. A value of 0.6 was assumed for the coefficient of friction.

6 Listed values indicate motor performance. Actual gradeability may be limited by grade clearance.
7 Loaded axle weights are based on 24" load center for English units and 500 mm for metric.

General Information	1	Manufacturer		Clark	Clark	
	2	Model	Manufacturer's Designation	TMX 20	TMX 25	
	3	Load Capacity	lbs(kg)	4000 (2000)	5000 (2500)	
	4	Load Center	Fork Face to Load CG	in(mm)	24 (500)	24 (500)
	5	Power Unit	Electric	36 volt 48 volt	36 volt 48 volt	
	6	Operator Type		Rider Counterbalanced	Rider Counterbalanced	
	7	Tire Type	Multi-Tire	Cushion Pneumatic	Cushion Pneumatic	
	8	Wheels (x=driven)	Front/Rear	2x / 1	2x / 1	
Basic Dimensions ²	9	Upright ¹	Maximum Fork Height, Full Capacity	in(mm)	171 (4346)	170 (4322)
	10		Lift Height (preferred Triple Stage)	in(mm)	188 (4781)	187 (4757)
	11		Free Lift, Triple Stage	in(mm)	59 (1500)	59 (1500)
	13	Upright Tilt	Back/Forward, TSU upright	degrees	5 / 3	5 / 3
	14	Forks	Std. Fork Size (T x W x L)	in(mm)	1.5 x 4 x 42 (40 x 100 x 1067)	1.5 x 4 x 42 (40 x 100 x 1067)
	15	Overall Dimensions	Length to Fork Face	in(mm)	76.1 (1933)	76.1 (1933)
	16		Width	in(mm)	40.25 (1022)	42.25 (1073)
	17		Height, Upright Lowered (188 TSU)	in(mm)	83 (2108)	83 (2108)
	18		Height, Upright Extended (188 TSU)	in(mm)	236 (5994)	235 (5969)
	19	Turning Radius		in(mm)	59.8 (1519)	61.9 (1565)
	20	Load Center Distance	Center of Drive Axle to Fork Face	in(mm)	14.4 (366)	14.4 (366)
	21					
	22	Right Angle Stack Aisle	Add Load Length and Clearance	in(mm)	74.2 (1885)	76.1 (1933)
	Performance ²	23	Stability	According to ANSI	Yes	Yes
24		Speeds	Travel Speed, Max w/ Load	mph(kph)	9.3 (15.0) 9.3 (15.0)	7.5 (12.0) 7.5 (12.0)
25			Travel Speed, Max w/o Load	mph(kph)	9.3 (15.0) 9.3 (15.0)	7.5 (12.0) 7.5 (12.0)
26		Lift/Lower Speeds, Loaded	Triple Stage	fpm(ms)	61(.31)/86(.43) 74(.39)/86(.43)	45(.23)/86(.43) 53(.27)/86(.43)
27		Lift/Lower Speeds, Empty	Triple Stage	fpm(ms)	104(.53)/77(.39) 118(.60)/77(.39)	89(.45)/77(.39) 95(.48)/77(.39)
28		Drawbar Pull (S2-60 min.)	Loaded ⁵	lbs(N)	1790(7960) 1630(7250)	1790(7960) 1630(7250)
29		Drawbar Pull (S2-5 min.)	Loaded ⁵	lbs(N)	4325(19235) 4325(19235)	4325(19235) 4325(19235)
30		Gradeability @ 1mph	Loaded ⁶	%	32 32	27 27
34			Unloaded ⁶	%	19 19	16 16
Weights ²		35	Service Weight	TSU Min Battery Weight (No Load)	lbs(kg)	8964 (4066)
	36	Axle Loading	With Load, Front ⁷	lbs(kg)	11692 (5405)	13401 (6206)
	37		With Load, Rear ⁷	lbs(kg)	1272 (661)	1692 (872)
	38		W/O Load, Front	lbs(kg)	4777 (2167)	4758 (2158)
	39		W/O Load, Rear	lbs(kg)	4187 (1899)	5335 (2420)
Chassis	40	Tires (Standard)	Number, Front/Rear		2 / 1	2 / 1
			Size, Front	in	18x8x12.12 18x9x8 16PR ⁴	18x9x12.12 NA
			Size, Rear	in	18x7x12.12 NA	18x6x12.12 ⁵ NA
	41		Size, Rear Dual Steer	in	15x5x11.25 15x4.5x8 ³	15x5x11.25 NA
	42	Wheelbase		in(mm)	52.7 (1339)	52.7 (1339)
	43	Track	Front, Cushion	in(mm)	32.3 (820)	33.3 (846)
	44		Front, Pneumatic	in(mm)	33.6 (853)	NA
	45	Ground Clearance	Min w/Load	in(mm)	3.25 (83)	3.25 (83)
	46		At Center of Wheelbase	in(mm)	4.1 (104)	4.1 (104)
	47	Service Brake	Type		Disc	Disc
	Parking Brake	Type		Hand lever actuated	Hand lever actuated	
48	Steering	Type		Hydrostatic	Hydrostatic	
Drive Line		Battery	Type		Lead-acid	Lead-acid
			Max Capacity (6 hr. Rate)	kWh	43.0	43.0
	49		Weight, Min	lbs(kg)	2590 (1176)	2590 (1176)
	50	Motors, Controls	Drive Motor, Diameter	in(mm)	7.9 (200)	7.9 (200)
	51		Hydraulic Motor Diameter	in(mm)	6.7 (170)	6.7 (170)
	52		Drive Motor Control		Inverter	Inverter
	53		Speed Control		Solid state	Solid state
	54		Hydraulic Motor Control		Inverter	Inverter
	55					
	56					
	57					
		Hydraulic Pressure	For Attachments	psi/bar	Adjustable	Adjustable

Notes: See previous pages for notes.

The Clark TMX Series electric three-wheel lift truck is designed to handle the most demanding industrial applications. Its compact size and tight-ratio steering make it highly maneuverable. Powerful induction motors make it responsive. A large operator's compartment and un-cluttered floorboards make it easy to operate. A tight turning radius allows operation in more confined areas than four-wheel models. Capacities up to 5000 LB allow the Clark TMX to perform where other trucks can't.

Operator Comfort / Convenience

- Low step height
- Steel step plates and grab handles on both sides
- Low-effort hydrostatic power steering
- Easy reach hand applied parking brake
- High visibility uprights
- Tilting steering pylon
- Dash display with operating and diagnostic information
- Planned Maintenance Alert

The large operator's compartment, low step height, slip-resistant steel step plates and grab handles make entry and exit from either side of the vehicle easy. The high visibility upright and longitudinal bar design of the overhead guard combine to provide optimum visibility in all directions. The TMX is equipped with a seat belt, Clark safety wing seat and battery restraint system to help protect the operator.

Lift/lower, tilt and auxiliary function levers are conveniently located on the cowl. The levers are offset from the seat centerline so the operator's right hand naturally falls on the levers. The steering wheel is offset to the left, also placing it in the correct position relative to the operator. A dash display provides continuous battery status, hour meter and a wide range of operational and diagnostic codes. A lift interrupt circuit assists in protecting the battery by disabling hydraulic operation when the battery is approximately 80% discharged. Hydraulic cushioning provides smooth, quiet staging of the upright.

AC Motors

- 100% AC system
- All motors are totally enclosed
- High torque drive motors provide high draw bar pull and gradeability

All motors used on the TMX are brushless induction motors, known for their simple yet rugged design. By eliminating brushes, Clark has made brush changes a thing of the past and the motors no longer have to be pulled from the truck for the commutator to be turned. All motors are totally enclosed to seal out contaminants such as dust and water and are equipped with a temperature monitoring device that signals the control to cut back power should motor temperatures ever approach their limit. Thermal protection is standard on all motors, as are encoders that provide accurate speed feedback to the control. The heavy-duty drive motors produce outstanding draw bar pull (up to twice that of some competitors), allowing the TMX to ascend grades that were once only negotiable by internal combustion trucks.

Electrical Controls

- AC Traction and Pump Controls
- Drive system stall warning
- Three forms of regenerative braking: accelerator pedal release, brake pedal actuation and reversing of the directional lever
- Ramp start and controlled roll-back features
- Accurate speed control
- High acceleration rates and rapid reversal of direction possible
- Fully adjustable to meet your specific needs
- Advanced thermal protection system
- High operating efficiency

Every TMX comes standard with a hydraulic pump control and fully proportional lift. The pump motor only spins as fast as the operator requests, expending only the needed energy. All controls are sealed so they are environmentally protected and

frame mounted high off the ground behind the counterweight for protection. The controls have low audible noise, improved acceleration and most importantly, increased operating time per battery charge. Being totally solid state controls, there are no forward, reverse or bypass (1A) contactors to service or contactor tips to replace. The standard motor encoder allows vehicle speed to be accurately regulated even under varying load and operating conditions. Regenerative braking maximizes energy returned to the battery. Self diagnostic capabilities of the control and storage of status codes aid trouble shooting and minimize downtime.

Drive Line

- Reliable "plug-in" drive motor design
- Drive axle housing supports pin mounted upright for reduced lost load

"Plug-in" drive motors with heavy mounting flanges mate the splined armature shafts directly to the axle assembly for positive alignment, improved heat dissipation and reliability. The intermediate gear shaft extends inward providing an accessible location for the disc brake assemblies.

Brakes

- Responsive pre-reduction disc brake
- Long service life

The Carlisle brake system has two disc brake assemblies located externally on the inboard side of the axle housing for easy access. This design provides smooth and responsive braking as brake torque is multiplied 23.4:1. Long brake life is also a benefit. Easy reach hand parking brake mechanically actuates both service brake assemblies.

Hydraulic System

- Hydraulic valve has adjustable flow control to accommodate attachment needs
- Quick connect port allows convenient pressure check
- Continuous fluid filtration
- O-ring face seal fittings reduce leaks and are easily serviced

Continuous fluid filtration within the power steering system, a 25 micron return line filter and a 10 micron filler cap/breather combine to provide maximum filtering efficiency. The tilt cylinder's design allows in-truck packing replacement.

Steering

- Quiet operation
- Full hydrostatic power steering

High maneuverability is achieved with steering angle of up to 90 degrees and proportional reversing of the inside drive wheel in tight turns. The outside drive tire powers the turn while the inside tire is powered in reverse, enhancing traction on slick or wet surfaces. The heavy-duty steer axle mount with tapered roller bearings provides high durability.

Uprights

- All-roller construction reduces friction and energy consumption
- Lateral side-thrust rollers on the fork carriage reduce friction caused by off-center loads
- Full I-section inner and intermediate rails provide maximum section strength
- Uprights accommodate 3/8 inch I.D. internal hosing for auxiliary functions requiring high flow rate
- Hydraulic cushioning on primary and secondary cylinders

Clark standard and triple stage uprights feature nested rail construction with cylinders behind the rails giving improved operator visibility. Tilt cylinder mounts are self-aligning to minimize side loading on cylinder rods for increased seal life. Hydraulic counter-balance valve in tilt circuit is designed to prevent cavitation. Load lowering and flow limiting control valves regulate carriage lowering speed, even in the event of a line failure. ITA Class II carriages with upset forged hook type forks with retainers.