

# CLARK CUSHION

## GEN2™ Series

### Cushion Tire Lift Trucks LPG/Dual Fuel

C20C	4,000 lbs 2000 kg
C25C	5,000 lbs 2500 kg
C30C	6,000 lbs 3000 kg
C32C	6,500 lbs 3200 kg

## C20/25/30/32C



For corresponding data see Specification Chart.

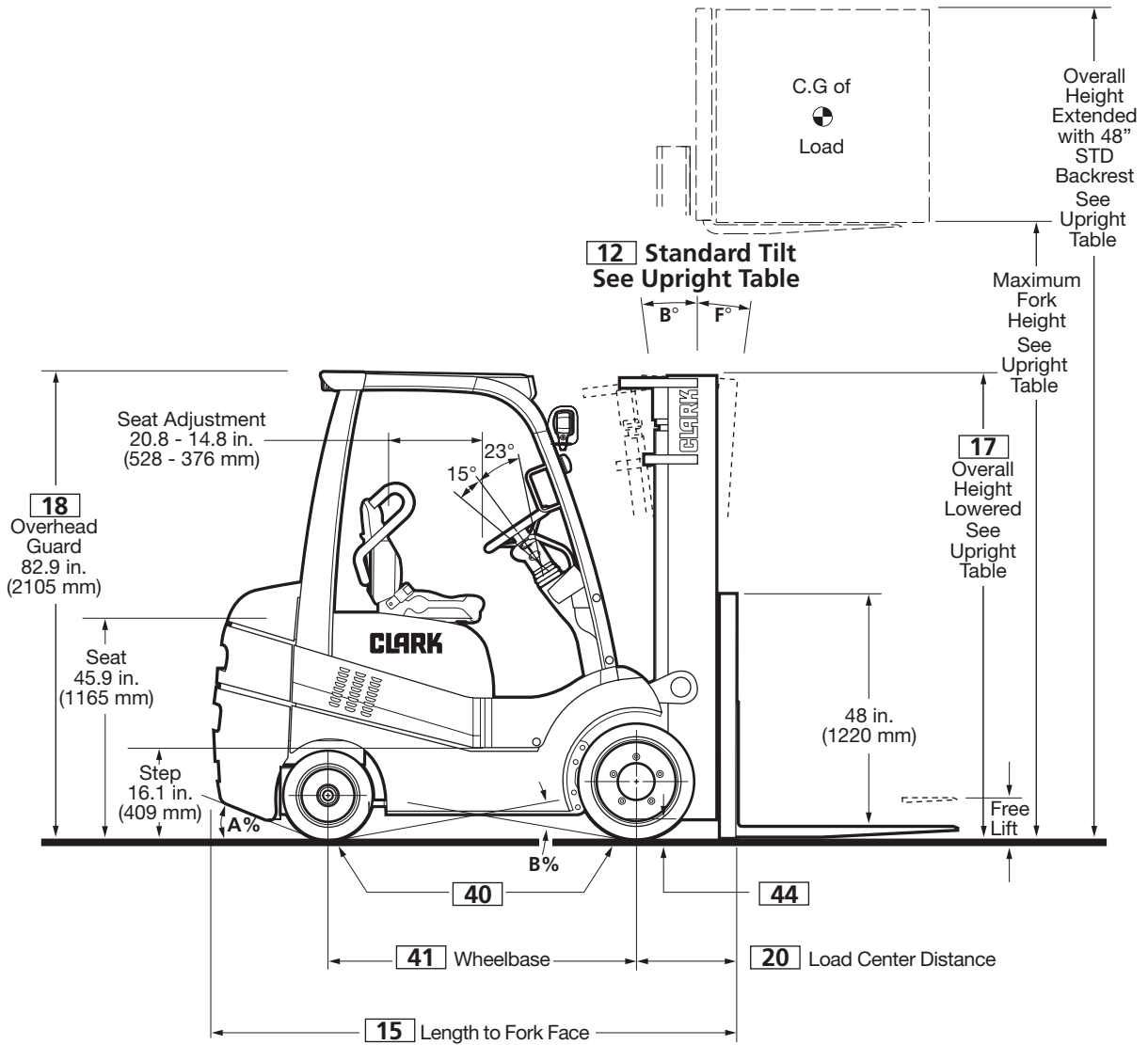

## C20/25/30/32C

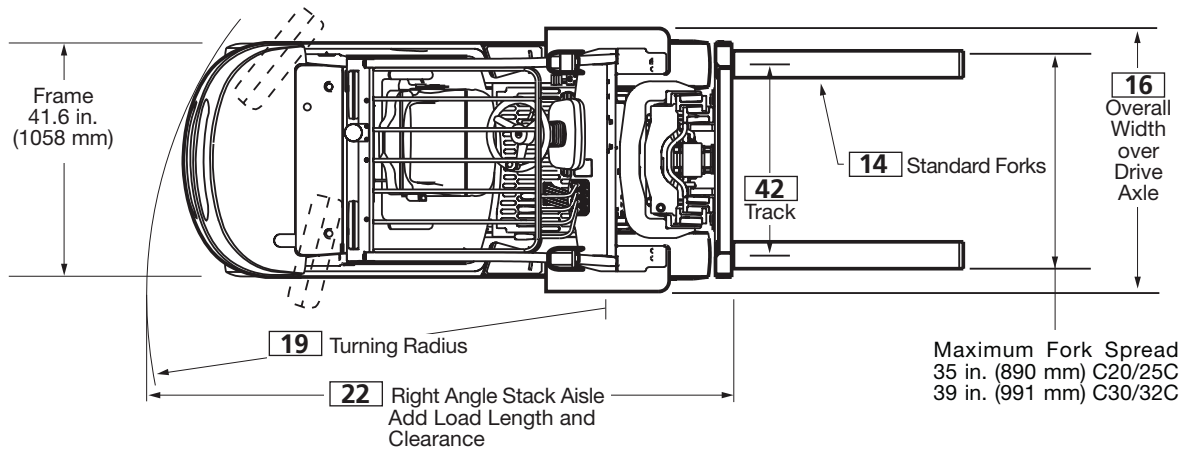

## Upright Table

Maximum Fork Height	Overall Height <sup>1</sup> Lowered	Free Lift <sup>4</sup>		Standard Tilt Spec <sup>2</sup>		
		in	mm		in	mm
<b>C20/25/30C Standard</b>						
83	2110	60.0	1525	4.3	110	6/10
105	2665	71.1	1806	4.3	110	8/10
117	2970	77.0	1955	4.3	110	8/10
•130	3300	83.3	2115	4.3	110	10/8
146	3705	94.7	2405	4.3	110	10/8
152	3860	97.6	2480	4.3	110	10/8
164	4165	108.3	2750	4.3	110	5/6
172	4380	116.1	2950	4.3	110	5/6
182	4620	125.2	3180	4.3	110	5/6
203	5170	135.6	3445	4.3	110	5/3

<b>C32C Standard</b>						
•127	3225	83.3	2120	4.5	115	8/10
144	3655	94.7	2415	4.5	115	10/8

<b>C20/25C Triple Stage<sup>3</sup></b>						
152	3860	71.1	1820	49.2	1252	5/6
170	4315	77.0	1955	55.2	1402	5/6
•189	4800	83.3	2119	61.5	1562	5/6
205	5205	88.8	2256	67.0	1702	5/3
217	5510	94.7	2405	72.9	1852	5/3
226	5740	97.6	2479	75.9	1927	5/3
240	6095	103.9	2639	82.2	2087	5/3
251	6370	108.3	2750	86.5	2197	3/3
269	6830	116.1	2950	94.4	2397	3/3
288	7315	125.2	3180	103.4	2627	3/3

<b>C30C Triple Stage<sup>3</sup></b>						
152	3860	71.1	1820	46.9	1192	5/6
170	4315	77.0	1955	52.8	1342	5/6
•189	4800	83.3	2119	59.1	1502	5/6
205	5205	88.8	2256	64.6	1642	5/3
217	5510	94.7	2405	70.6	1792	5/3
226	5740	97.6	2479	73.5	1867	5/3
240	6095	103.9	2639	79.8	2027	5/3
251	6370	108.3	2750	84.1	2137	3/3
269	6830	116.1	2950	92.0	2337	3/3
288	7315	125.2	3180	101.1	2567	3/3

<b>C32C Triple Stage<sup>3</sup></b>						
164	4165	77.0	1960	51.0	1296	5/6
•189	4800	85.4	2170	59.5	1511	5/6
199	5055	89.0	2265	62.8	1596	5/3
211	5355	95.0	2415	68.7	1746	5/3

<b>C20/25C Hi-Lo</b>						
115	2935	77	1956	55.2	1403	8/8
•128	3250	83.3	2116	61.5	1563	8/8
139	3531	88.8	2256	67.0	1703	8/8
148	3760	94.7	2405	73.0	1853	8/8
154	3912	97.6	2479	75.9	1928	8/8

<b>C30C Hi-Lo</b>						
115	2935	77	1956	52.8	1342	8/8
•128	3250	83.3	2116	59.1	1502	8/8
139	3531	88.8	2256	64.6	1642	8/8
148	3760	94.7	2405	70.6	1792	8/8
154	3912	97.6	2479	73.5	1867	8/8

<b>C20/25/30C Quad<sup>3</sup></b>						
216	5485	77	1956	52.0	1320	3/0
•240	6096	83	2108	58.0	1473	3/0
258	6553	89	2260	64.0	1625	3/0
276	7010	95	2413	70.0	1778	3/0
294	7465	101	2565	76.0	1930	3/0
312	7925	107	2718	82.0	2082	3/0

## Grade Clearance

Model	A%	B%
C20/25/30/32C	39.4	16.3

## Available Equipment

- Auxiliary valves
- Hose adaptations
- Sideshifters
- Hydraulic control options
- Unitrol foot directional control
- Combination stop/tail/backup lights
- Rear work light
- Turn signal lights
- Strobe lights
- Backup alarm
- Mirrors
- Convenience console
- Suspension seat, vinyl and cloth
- Reduced height overhead guard
- U.L. Type LPS construction
- Seat actuated engine shutdown
- Pre-cleaner – overhead guard mounted
- Air cleaner safety element
- Dual fuel
- CNG
- Travel Speed Limit - with Full Hydraulic Speed
- Belly pan
- Radiator screen
- Clean Air Cooling Package
- Bottler's tilt

## Notes

Production engines and driveline components may vary in output and/or efficiency by  $\pm 5\%$ . The performance shown represents nominal values which may be obtained under typical operating conditions of a machine.

Clark products and specifications are subject to change without notice.

© Clark Material Handling Company 2005.

## ASME and Insurance Classification

Standard truck meets all applicable mandatory requirements of ASME-B56.1 Safety Standard for Powered Industrial Trucks and Underwriters Laboratories requirements as to fire hazard only for LP and LPS classifications. For further information contact a Clark representative.

## For Your Safety

Before operating a lift truck, an operator must:

- Be trained and authorized
- Read and understand the operator's manual
- Not operate a faulty lift truck
- Not repair a lift truck unless trained and authorized
- Have the overhead guard and load backrest extension in place

During operation, a lift truck operator must:

- Wear a seat belt
- Keep entire body inside truck cab
- Never carry passengers or lift people
- Keep truck away from people and obstructions
- Travel with lift mechanism as low as possible and tilted back

To park a lift truck, an operator must:

- Completely lower forks or attachments
- Shift into neutral
- Turn key off
- Set parking brake

Contact your Clark dealer for operator training information.

- Indicates preferred common specification.
- <sup>1</sup> For overall height raised with load backrest, add 48 in. (1220 mm) to maximum fork height.
- <sup>2</sup> Standard tilt shown. Contact Clark representative for information on optional tilt.
- <sup>3</sup> Wide stance wheel (standard tire) is provided with all Quad uprights and all triple stage uprights over 240 in. (6095 mm) Maximum Fork Height – overall truck width is 48.8 in. (1240 mm) on C20/25C and 50.8 in. (1290 mm) on the C30/32C.
- <sup>4</sup> Freelif dimensions shown are without load backrest.

Other uprights available, contact a Clark representative.

General Information	1	Manufacturer		Clark	Clark	
	2	Model	Manufacturer's designation	C20CL	C25CL	
	3	Load capacity		lbs(kg)	4000 (2000)	5000 (2500)
	4	Load center	Fork face to load CG	in(mm)	24 (500)	24 (500)
	5	Drive unit	Type		LPG	LPG
	6	Operator type			Rider counterbalanced	Rider counterbalanced
	7	Tire type			Cushion	Cushion
	8	Wheels (x=driven)	Front/rear		2 x / 2	2 x / 2
Basic Dimensions <sup>1</sup>	9	Upright <sup>1</sup>	Maximum fork height, full capacity	in(mm)	189 (4800)	189 (4800)
	10		Lift height (preferred triple upright)	in(mm)	189 (4800)	189 (4800)
	11		Free lift <sup>1</sup>	in(mm)	54.0 (1327)	54.0 (1372)
	12	Upright tilt	Back/forward (see tilt specifications)	degrees	5B / 6F	5B / 6F
	14	Fork	Std. Fork size (TxWxL)	in(mm)	1.75x4x42 (45x100x1070)	1.75x4x42 (45x100x1070)
	15	Overall dimensions <sup>1</sup>	Length to fork face <sup>1,2</sup>	in(mm)	88.5 (2248)	90.9 (2310)
	16		Width over drive axle	in(mm)	42.5 (1080)	42.5 (1080)
	17		Height, upright lowered <sup>1</sup>	in(mm)	83.5 (2120)	83.5 (2120)
			Height, upright extended w/ load backrest <sup>1</sup>	in(mm)	237 (6020)	237 (6020)
	18		Height, overhead guard	in(mm)	82.8 (2105)	82.8 (2105)
	19	Turning radius	Outside	in(mm)	77.8 (1975)	80.1 (2035)
	20	Load center distance <sup>1,2</sup>	Center of drive axle to fork face <sup>1,2</sup>	in(mm)	16.7 (424)	16.7 (424)
22	Right angle stack aisle <sup>1,2</sup>	Add load length and clearance <sup>1,2</sup>	in(mm)	94.5 (2399)	96.8 (2459)	
Performance <sup>1,2,3</sup>	23	Stability	According to ASME B56.1		Yes	Yes
	24	Speed <sup>3</sup>	Travel speed, max w/load	mph(kph)	10.4 (16.8)	10.4 (16.8)
	25		Travel speed, max w/o load	mph(kph)	10.4 (16.8)	10.4 (16.8)
		Speed on grade, loaded <sup>3</sup>	5%, loaded <sup>3</sup>	mph(kph)	9.9 (16.0)	9.7 (15.7)
			10%, loaded <sup>3</sup>	mph(kph)	5.8 (9.4)	5.5 (8.9)
			15%, loaded <sup>3</sup>	mph(kph)	4.5 (7.3)	3.9 (6.3)
	26	Lift speed, loaded/empty <sup>3</sup>	Standard upright <sup>3</sup>	fpm(ms)	106/124 (.54/.63)	104/124 (.53/.63)
	28		Triple stage upright <sup>3</sup>	fpm(ms)	102/126 (.52/.61)	100/120 (.51/.61)
	29	Lower speed,loaded/empty	Standard upright	fpm(ms)	89/89 (.45/.45)	89/89 (.45/.45)
			Triple stage upright	fpm(ms)	85/85 (.43/.43)	85/85 (.43/.43)
30	Drawbar pull, maximum <sup>1,3</sup>	With load <sup>3</sup>	lbs/N	4850 / 21570	4850 / 21570	
32	Gradeability <sup>1,3</sup>	At 1 mph (1.6 kph) with load <sup>3</sup>	%	34.2	29.1	
		Maximum with/without load <sup>1,3</sup>	%	39.5 / 26.2	33.2 / 21.7	
Weights <sup>1</sup>	34	Service weight <sup>1</sup>		lbs(kg)	8,137 (3691)	8955 (4062)
	35	Axle loading <sup>1</sup>	With load, front <sup>1</sup>	lbs(kg)	11,122 (5045)	12,712 (5766)
	36		With load, rear <sup>1</sup>	lbs(kg)	1424 (646)	1755 (796)
	37		Without load, front <sup>1</sup>	lbs(kg)	3796 (1722)	3554 (1612)
	38		Without load, rear <sup>1</sup>	lbs(kg)	4341 (1969)	5401 (2450)
Chassis	39	Tires	Number, front/rear		2 / 2	2 / 2
	40		Size, front	in	21x7x15	21x7x15
			Size, rear	in	16x5x10.5	16x5x10.5
	41	Wheelbase		in(mm)	55.1 / 1400)	55.1 / 1400)
	42	Track	Front/rear	in(mm)	34.7 /35.2 (882/895)	34.7/35.2 (882/895)
	44	Ground clearance	Minimum/at center of wheelbase	in(mm)	3.35/4.3 (85/110)	3.35/4.3 (85/110)
	46	Service brake	Type		Drum	Drum
	47	Parking brake	Actuation		Foot	Foot
	Steering	Type		Hydrostatic	Hydrostatic	
Drive Line	49	Engine <sup>3,4</sup>	Manufacturer/model		Mitsubishi / 4G64	Mitsubishi / 4G64
	51		Rated output <sup>3,4</sup>	HP/kW@rpm	47.5 / 35.4 @ 2250	47.5 / 35.4 @ 2250
			Torque <sup>3,4</sup>	Lb-ft/Nm@rpm	120 / 163 @ 1400	120 / 163 @ 1400
	52		Speed, max governed	rpm	2650	2650
	53		Cylinders/displacement	cu. In.-liters	4 / 143 - 2.4	4 / 143 - 2.4
54	Transmission	Manufacturer/type, speeds F/R		Clark/Powershift, 1/1	Clark/Powershift, 1/1	
57	Hydraulic pressure	For attachments	PSI/Bar	Adjustable	Adjustable	
58	Sound level	Avg. at operator's ear per ISO	dB(A)	78	78	

**Notes:** 1 Weights and performance information are given on trucks with 189 in. (4800 mm) triple uprights.  
2 For standard upright, deduct 1.3 in. (33 mm).

3 Performance information shown for LPG.  
4 Engines rated per SAE J1349.

General Information	1	Manufacturer		Clark	Clark		
	2	Model	Manufacturer's designation	C30CL	C32CL		
	3	Load capacity		lbs(kg)	6000 (3000)	6500 (3200)	
	4	Load center	Fork face to load CG	in(mm)	24 (500)	24 (500)	
	5	Drive unit	Type		LPG	LPG	
	6	Operator type			Rider counterbalanced	Rider counterbalanced	
	7	Tire type			Cushion	Cushion	
	8	Wheels (x=driven)	Front/rear		2 x / 2	2 x / 2	
Basic Dimensions <sup>1</sup>	9	Upright <sup>1</sup>	Maximum fork height, full capacity	in(mm)	189 (4800)	164 (4165)	
	10		Lift height (preferred triple upright)	in(mm)	189 (4800)	189 (4800)	
	11		Free lift <sup>1</sup>	in(mm)	54.0 (1372)	53.4 (1356)	
	12	Upright tilt	Back/forward (see tilt specifications)	degrees	5B / 6F	5B / 6F	
	14	Fork	Std. Fork size (TxWxL)	in(mm)	1.75x4.8x42 (45x122x1070)	2x4.8x42 (50x122x1070)	
	15	Overall dimensions <sup>1</sup>	Length to fork face <sup>1,2</sup>	in(mm)	92.9 (2359)	95.2 (2417)	
	16		Width over drive axle	in(mm)	43.7 (1110)	45.4 (1154)	
	17		Height, upright lowered <sup>1</sup>	in(mm)	83.5 (2120)	85.4 (2170)	
			Height, upright extended w/ load backrest <sup>1</sup>	in(mm)	237 (6020)	237 (6020)	
	18		Height, overhead guard	in(mm)	82.8 (2105)	82.8 (2105)	
	19	Turning radius	Outside	in(mm)	82.3 (2090)	83.9 (2130)	
	20	Load center distance <sup>1,2</sup>	Center of drive axle to fork face <sup>1,2</sup>	in(mm)	16.9 (429)	17.5 (445)	
	22	Right angle stack aisle <sup>1,2</sup>	Add load length and clearance <sup>1,2</sup>	in(mm)	99.2 (2519)	101.4 (2575)	
	Performance <sup>1,2,3</sup>	23	Stability	According to ASME B56.1		Yes	Yes
24		Speed <sup>3</sup>	Travel speed, max w/load	mph(kph)	10.3 (16.7)	10.2 (16.5)	
25			Travel speed, max w/o load	mph(kph)	10.3 (16.7)	10.2 (16.5)	
			Speed on grade, loaded <sup>3</sup>	5%, loaded <sup>3</sup>	mph(kph)	9.4 (15.2)	9.2 (15.2)
				10%, loaded <sup>3</sup>	mph(kph)	5.2 (8.4)	5.0 (8.1)
				15%, loaded <sup>3</sup>	mph(kph)	3.7 (6.0)	3.5 (5.7)
26		Lift speed, loaded/empty <sup>3</sup>	Standard upright <sup>3</sup>	fpm(ms)	102/124 (.52/.63)	102/124 (.52/.63)	
28			Triple stage upright <sup>3</sup>	fpm(ms)	98/120 (.50/.61)	96/120 (.49/.61)	
29		Lower speed,loaded/empty	Standard upright	fpm(ms)	89/89 (.45/.45)	89/89 (.45/.45)	
			Triple stage upright	fpm(ms)	85/85 (.43/.43)	85/85 (.43/.43)	
30		Drawbar pull, maximum <sup>1,3</sup>	With load <sup>3</sup>	lbs/N	4850 / 21570	4850 / 21570	
32	Gradeability <sup>1,3</sup>	At 1 mph (1.6 kph) with load <sup>3</sup>	%	25.3	22.0		
		Maximum with/without load <sup>1,3</sup>	%	28.3 / 18.4	26.8 / 17.4		
Weights <sup>1</sup>	34	Service weight <sup>1</sup>		lbs(kg)	9899 (4490)	10,254 (4651)	
	35	Axle loading <sup>1</sup>	With load, front <sup>1</sup>	lbs(kg)	14,358 (6513)	15,064 (6833)	
	36		With load, rear <sup>1</sup>	lbs(kg)	2154 (977)	2244 (1018)	
	37		Without load, front <sup>1</sup>	lbs(kg)	3369 (1528)	3318 (1505)	
	38		Without load, rear <sup>1</sup>	lbs(kg)	6530 (2962)	6936 (3146)	
Chassis	39	Tires	Number, front/rear		2 / 2	2 / 2	
	40		Size, front	in	21x8x15	21x9x15	
			Size, rear	in	16x6x10.5	16x6x10.5	
	41	Wheelbase		in(mm)	55.1 (1400)	55.1 (1400)	
	42	Track	Front/rear	in(mm)	35.7/36.2 (908/920)	36.7/36.2 (932/920)	
	44	Ground clearance	Minimum/at center of wheelbase	in(mm)	3.35/4.3 (85/110)	3.35/4.3 (85/110)	
	46	Service brake	Type		Drum	Drum	
	47	Parking brake	Actuation		Foot	Foot	
	Steering	Type		Hydrostatic	Hydrostatic		
Drive Line	49	Engine <sup>3,4</sup>	Manufacturer/model		Mitsubishi / 4G64	Mitsubishi / 4G64	
	51		Rated output <sup>3,4</sup>	HP/kW@rpm	47.5 / 35.4 @ 2250	47.5 / 35.4 @ 2250	
			Torque <sup>3,4</sup>	Lb-ft/Nm@rpm	120 / 163 @ 1400	120 / 163 @ 1400	
	52		Speed, max governed	rpm	2650	2650	
	53		Cylinders/displacement	cu. In.-liters	4 / 143 - 2.4	4 / 143 - 2.4	
	54	Transmission	Manufacturer/type, speeds F/R		Clark/Powershift, 1/1	Clark/Powershift, 1/1	
57	Hydraulic pressure	For attachments	PSI/Bar		Adjustable	Adjustable	
58	Sound level	Avg. at operator's ear per ISO	dB(A)		78	78	

**Notes:** 1 Weights and performance information are given on trucks with 189 in. (4800 mm) triple uprights.  
2 For standard upright, deduct 1.3 in. (33 mm).

3 Performance information shown for LPG.  
4 Engines rated per SAE J1349.

**CLARK Gen2 Series** cushion tire trucks are designed for applications in manufacturing, warehousing and distribution. The standard design features provide high levels of operator comfort, reliability, ease of service and low noise to meet the most demanding operations.

### Operator Comfort / Convenience

Gen2 Series trucks feature a rubber isolated operator cell that provides a quiet, comfortable and spacious environment for operators of all sizes. The large floor area is free of obstructions, easily removable without tools and covered with a thick, molded floor mat. Large open steps and grab handles assist entry and exit from both sides. Two-pedal inch-brake system has low height, short travel pedals. Left pedal is for inch and brake operation; right pedal is for brakes only. Left foot actuated parking brake.

Hydraulic control levers are cowl-mounted. Left hand fingertip operated directional control is electrically actuated. Equipped with a legendary CLARK safety seat with shoulder restraints, adjustable and fold-down back rest, molded bolsters for comfort and support, six inches (150mm) fore/aft adjustment, a retractable seat belt and an operator manual in the seat pocket. Visual and audio seat belt prompt on start-up. Tilt steering column locks in one of six positions; 38° total travel. Small, thick section wheel, with four turns lock-to-lock, is easily operated with one hand. Clamshell hood with gas struts gives easy access for daily inspections.

### Instrument Panel

The instrument panel features a full LED/digital display with visual and audible engine monitoring warnings. Functions being monitored include water temperature, engine oil pressure, transmission oil temperature, ammeter, and low fuel. It also features fuel system diagnostics with indicator, programmable maintenance timer and touch pad light switches, hour meter, neutral start system and anti-restart. An automatic engine shutdown system continuously monitors engine oil pressure, engine coolant temperature and transmission oil temperature. The instrument panel includes prompts for the seat belt, parking brake, ignition key, headlights, service engine light and is warranted for 2 years or 4000 hours.

### Engine

Mitsubishi model 4G64, 2.4-liter (143 CI) 4-cylinder overhead cam engine with internal dynamic balancers and an EPA certified, low-emission LPG or dual fuel system with diagnostics. Camshaft and balancers are cog belt driven. Cast iron deep skirt block with aluminum cylinder head and 5-main bearing crankshaft.

Hydraulic valve lifters and electronic ignition reduce maintenance requirements. Either 33.5 lb. (15.2 kg) or 43.5 lb. (19.7 kg) tanks can be used.

### Engine Accessories/Capacities

Trucks are 12-volt negative ground and incorporate a heavy-duty starter. Batteries are rated at 550 CCA at 0° F (-18° C). High capacity air cleaners with raised air intake, automatic dirt ejectors and an air restriction indicator for service. An optional air cleaner safety element and pre-cleaner can be added without other changes. A fuse panel with blade type fuses and relays is conveniently located. Moisture resistant electrical connectors and fusible links are located outside of harness for ease of access. Filters are easily serviced and located to prevent spillage. Crankcase capacity is 4.0 qts. (3.8 L).

### Transaxle

Clark model TA 30 full reversing, single speed, powershift transaxle with high stall ratio industrial torque converter, full-floating drive axles, and drum/shoe brake assemblies. Solenoid actuated, hydraulically modulated directional control and mechanically actuated, hydraulic inching. Helical drive gears operate smoothly and reduce noise. The gear-driven hydraulic pump is transmission mounted. Control elements and test ports readily accessible for service. Heavy-duty transmission cooler, mounted integral in a high efficiency, open

core radiator, provides independent transmission cooling. The full-flow transmission spin-on oil filter and sump screen are easily serviced.

### Brakes

Self-energizing, hydraulically-actuated drum and shoe type service brakes. Shrouds prevent dirt entry into the brake area. Inching and brake operation with left pedal, braking only with right pedal. Heavy backing plates, brake shoes and drums with openings for inspection and adjustment; all components asbestos-free. Brakes are self adjusting and quickly accessed by removing wheel and brake drum; no axle removal is required. Use of the parking brake, with electric transmission interrupt, prevents driving against the brakes. Left foot parking brake pedal actuates service brakes at both drive wheels. A dual stage master cylinder assures smooth braking and reduced pedal effort with short pedal stroke.

### Hydraulics

Single gear pump provides fluid for hydraulic functions and steering. Priority-demand steering system conserves energy by supplying hydraulic fluid on demand-only basis. Hydraulic tank is integral with truck frame. An in-tank return line filter is quickly changed without spill. A quick-connect pressure port on the pump enables convenient pressure checks. All pressure fittings utilize O-ring face seals for leak-free operation. Sump tank capacity is 8.0 gal. (30.2 L).

### Steering

Full hydrostatic steering. A compact axle beam with an integral double acting steer cylinder. Spindle assemblies incorporate king pins with tapered roller bearings to provide a rugged yet easily serviced assembly. Rubber isolation mounts supporting the axle absorb shock and reduce noise. Metal shields protect spindle bearing seals from wire or in-plant debris. Grease fittings extend linkage and bearing service life.

### Upright

High visibility standard, Hi-Lo, triple stage and Quad uprights of heavy C-channel outer rails and full I-section inner and intermediate rails. A wide range of lift heights are available. All-roller operation of upright rails and carriage. Rollers are canted to accept both normal and side thrust loads. The ITA Class II and III carriages employ six main rollers with two inner and two outer thrust rollers to absorb off-center loading. The load backrest is designed for optimum visibility. Hydraulic cushioning between stages aids in smooth and quiet operation. Self-lubricating trunion bushings and simplified roller access improve serviceability. Hydraulic tilt lock valve prevents improper tilt cylinder operation; integral flow limiting valves prevent rapid carriage descent in the event of a line failure; and a lowering control valve allows faster lowering speeds when empty or with light loads.

### Additional Features

A single auxiliary valve and two headlights mounted on the overhead guard are standard equipment. The auxiliary hydraulic flow can be easily adjusted at the main valve to match the flow requirements of different attachments. With a one-piece hood and quickly removable floorplate, all routine maintenance checkpoints are readily accessible. The operator cell is designed for operator comfort and productivity. An Operator Manual is permanently attached inside the rear pocket of the comfortable safety seat. Color is high visibility Clark Green with non-glare matte black trim and white wheels. Tow pin in the counterweight is standard.

### Available Equipment

Auxiliary valves, hose adaptations, sidershifters, hydraulic control options, Unitrol foot directional control, combination stop/tail/backup lights, rear work light, turn signals, strobe lights, backup alarm, mirrors, convenience console, various seat options, reduced height overhead guard, U.L. Type LPS construction, seat actuated engine shutdown, high mounted pre-cleaner, air cleaner safety element, dual fuel, CNG, belly pan and radiator screen options to prevent radiator plugging, Paper Recycling Package, Bottler's tilt.



---

 **North America CMHC**  
Worldwide Headquarters  
700 Enterprise Drive  
Lexington, KY 40510  
**866-252-5275**  
[www.clarkmhc.com](http://www.clarkmhc.com)

your authorized CLARK dealer is: