

16-CUSHION

Cushion Tire Lift Trucks LPG

CGC40
CGC50
CGC55

8,000 lbs 4000 kg
10,000 lbs 5000 kg
12,000 lbs 5500 kg

CGC40/50/55

Genesis™ Series



CLARK
BUILT TO LAST.®

w w w . c l a r k m h c . c o m

For corresponding data see Specification Chart.

Optional "Q" Counterweight

Stacked counterweight design shortens overall truck length for increased maneuverability in confined areas. "Q" Counterweight package does not include tow pin. Truck specifications change as noted below.

CGC40 with "Q" Counterweight Option

| | |
|-------------------------------|---------------------|
| Overall Length to fork face | 94.9 in. (2410 mm) |
| Counterweight height | 57.5 in. (1460 mm) |
| Turning Radius | 84.1 in. (2136 mm) |
| Right Angle Stack Aisle | 101.4 in. (2575 mm) |
| Add load length and clearance | |

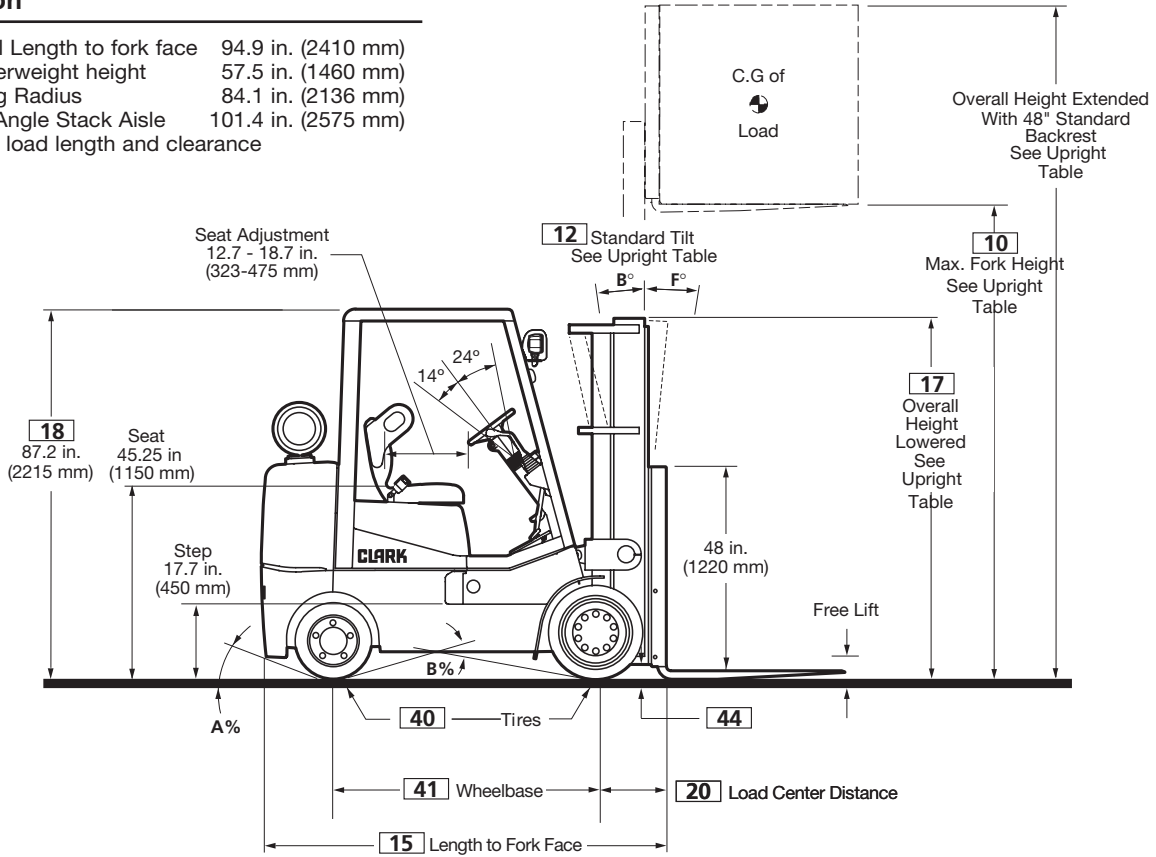

CGC40/50/55

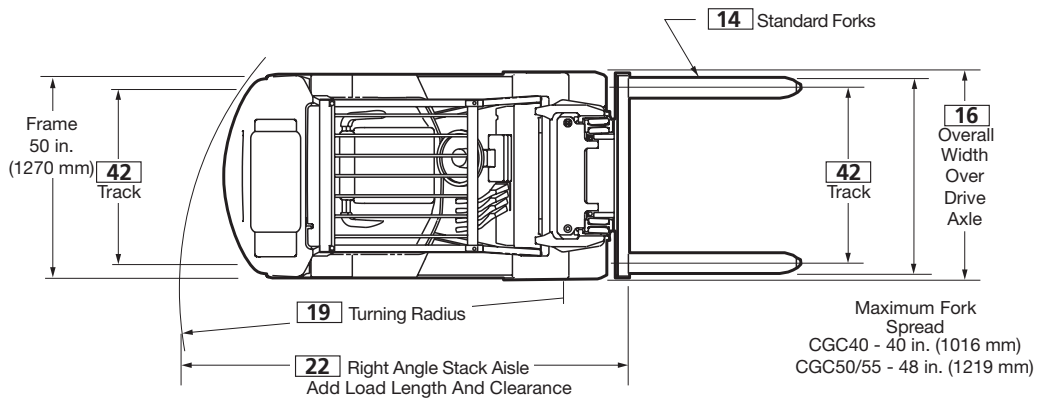

Upright Table

| Maximum Fork Height in mm | Overall Height ¹ Lowered | | Free Lift ³ | | Standard ² Tilt Spec B°/F° | |
|------------------------------|--|-------|------------------------|-----|---|-----|
| | in | mm | in | mm | | |
| CGC40 | | | | | | |
| Standard | | | | | | |
| 110 | 2794 | 83.2 | 2114 | 6.5 | 165 | 8/9 |
| • 122 | 3073 | 89.1 | 2264 | 6.5 | 165 | 8/9 |
| 145 | 3683 | 101 | 2565 | 6.5 | 165 | 5/6 |
| 169 | 4293 | 112.7 | 2864 | 6.5 | 165 | 5/6 |
| Triple Stage | | | | | | |
| 170 | 4328 | 83 | 2106 | 57 | 1453 | 5/6 |
| • 188 | 4778 | 89 | 2256 | 63 | 1603 | 5/6 |
| 198 | 5039 | 98 | 2481 | 72 | 1828 | 5/3 |
| 211 | 5378 | 101 | 2556 | 75 | 1903 | 5/3 |
| 229 | 5829 | 107 | 2706 | 80 | 2053 | 5/3 |
| 253 | 6428 | 118.5 | 3006 | 92 | 2353 | 3/0 |
| CGC50 | | | | | | |
| Standard | | | | | | |
| 104 | 2645 | 84 | 2131 | 6.5 | 174 | 8/9 |
| • 116 | 2945 | 90 | 2281 | 6.5 | 174 | 8/9 |
| 140 | 3530 | 102 | 2581 | 6.5 | 174 | 8/9 |
| 163 | 4140 | 113.4 | 2881 | 6.5 | 174 | 5/6 |
| Triple Stage | | | | | | |
| 162 | 4115 | 83.5 | 2117 | 49 | 1258 | 5/6 |
| • 178 | 4529 | 89.5 | 2667 | 55 | 1408 | 5/6 |
| 190 | 4825 | 95.5 | 2417 | 61 | 1558 | 5/3 |
| 198 | 5029 | 101 | 2567 | 67 | 1708 | 5/3 |
| 220 | 5578 | 107 | 2717 | 78 | 1858 | 5/3 |
| 243 | 6178 | 119 | 3017 | 85 | 2158 | 3/0 |
| CGC55 | | | | | | |
| Standard | | | | | | |
| 100 | 2540 | 84 | 2132 | 6.9 | 175 | 8/9 |
| • 112 | 2845 | 90 | 2281 | 6.9 | 175 | 8/9 |
| 135 | 3430 | 102 | 2582 | 6.9 | 175 | 8/9 |
| 159 | 4040 | 114 | 2882 | 6.9 | 175 | 5/6 |
| Triple Stage | | | | | | |
| 152 | 3874 | 83.5 | 2117 | 51 | 1298 | 5/6 |
| • 169 | 4288 | 89.5 | 2267 | 57 | 1448 | 5/6 |
| 180 | 4588 | 95.5 | 2417 | 63 | 1598 | 5/6 |
| 192 | 4876 | 99.0 | 2515 | 64 | 1625 | 5/3 |
| 210 | 5338 | 107 | 2717 | 74 | 1898 | 5/3 |
| 234 | 5938 | 119 | 3017 | 86 | 2198 | 3/0 |

Grade Clearance

| Model | A% | B% |
|-------|----|----|
| CGG40 | 39 | 22 |
| CGC50 | 40 | 19 |
| CGC55 | 35 | 19 |

- Indicates preferred standard sizes.
- ¹ For overall height raised with load backrest, add 48 in. (1220 mm) to maximum fork height.
- ² Standard Tilt shown. Contact a Clark representative for information on optional tilt.
- ³ Freelif dimensions shown are without load backrest.

Other uprights available, contact a Clark representative.

Available Equipment

- Auxiliary valves
- Hose adaptations
- Sideshifters
- Hydraulic control options
- Unitrol foot directional control
- Combination stop/tail/backup lights
- Rear work light
- Turn signal lights
- Strobe lights
- Backup alarm
- Mirrors
- Convenience console
- Suspension seat, vinyl and cloth
- Operator cab with heater
- Reduced height overhead guard
- U.L. Type LPS construction
- Seat actuated engine shutdown
- Pre-cleaner - overhead guard mounted
- Air cleaner safety element
- Two-speed Transmission
- Travel Speed Limit
- Short turning radius counterweight
- Bottler's tilt
- Louvered Hood
- Lift Eyes
- Tire Options

Notes

Production engines and driveline components may vary in output and/or efficiency by $\pm 5\%$. The performance shown represents nominal values which may be obtained under typical operating conditions of a machine.

Clark products and specifications are subject to change without notice.

© Clark Material Handling Company 2005.

ANSI and Insurance Classification

Standard truck meets all applicable mandatory requirements of ANSI-B56.1 Safety Standard for Powered Industrial Trucks and Underwriters Laboratories requirements as to fire hazard only for LP, and LPS classifications. For further information contact a Clark representative.

For Your Safety

Before operating a lift truck, an operator must:

- Be trained and authorized
- Read and understand the operator's manual
- Not operate a faulty lift truck
- Not repair a lift truck unless trained and authorized
- Have the overhead guard and load backrest extension in place

During operation, a lift truck operator must:

- Wear a seat belt
- Keep entire body inside truck cab
- Never carry passengers or lift people
- Keep truck away from people and obstructions
- Travel with lift mechanism as low as possible and tilted back

To park a lift truck, an operator must:

- Completely lower forks or attachments
- Shift into neutral
- Turn key off
- Set parking brake

Contact your Clark dealer for operator training information.

| | | | | | | |
|-----------------------------------|-------------------------|--|--|----------------------|----------------------------------|----------------------------------|
| General Information | 1 | Manufacturer | | Clark | Clark | |
| | 2 | Model | Manufacturer's designation | CGC 40 | CGC 50 | |
| | 3 | Load capacity | | lbs(kg) | 8,000 (4000) | 10,000 (5000) |
| | 4 | Load center | Fork face to load CG | in(mm) | 24 (500) | 24 (500) |
| | 5 | Drive unit | Type | | LPG | LPG |
| | 6 | Operator type | | | Rider counterbalanced | Rider counterbalanced |
| | 7 | Tire type | | | Cushion | Cushion |
| | 8 | Wheels (x=driven) | Front/rear | | 2 x / 2 | 2 x / 2 |
| Basic Dimensions ^{1,2,3} | 9 | Upright ^{1,2} | Maximum fork height, full capacity | in(mm) | 198 (5030) | 198 (5030) |
| | 10 | | Lift height (preferred triple upright) | in(mm) | 188 (4778) | 178 (4529) |
| | 11 | | Free lift ¹ | in(mm) | 6.5 (165) | 6.5 (165) |
| | 12 | Upright tilt | Back/forward (see tilt specifications) | degrees | 8 / 9 | 8 / 9 |
| | 14 | Fork | Std. Fork size (TxWxL)/Class | in(mm) | 2 x 5 x 42 (50 x 127 x 1067)/III | 2 x 6 x 48 (50 x 152 x 1220)/III |
| | 15 | Overall dimensions | Length to fork face ² | in(mm) | 96.0 (2438) | 105.2 (2672) |
| | 16 | | Width over drive axle | in(mm) | 50.8 (1290) | 54.8 (1392) |
| | 17 | | Height, upright lowered ¹ | in(mm) | 89.1 (2264) | 90.0 (2281) |
| | | | Height, upright extended w/ load backrest ¹ | in(mm) | 170 (4320) | 164 (4165) |
| | 18 | | Height, overhead guard ³ | in(mm) | 87.2 (2215) | 87.2 (2215) |
| | 19 | Turning radius | Outside | in(mm) | 89.4 (2270) | 98.2 (2494) |
| | 20 | Load center distance | Center of drive axle to fork face ² | in(mm) | 17.3 (439) | 17.8 (452) |
| 22 | Right angle stack aisle | Add load length and clearance ² | in(mm) | 106.7 (2710) | 116.0 (2946) | |
| Performance ^{1,3} | 23 | Stability | According to ANSI/B56.1 | | Yes | Yes |
| | 24 | Speed | Travel speed, max w/load | mph(kph) | 12.2 (19.6) | 12.1 (19.5) |
| | 25 | | Travel speed, max w/o load | mph(kph) | 12.5 (20.1) | 12.4 (20.0) |
| | | | Speed on grade, loaded | | | |
| | | | 5%, loaded | mph(kph) | 9.5 (15.3) | 9.0 (14.4) |
| | | | 10%, loaded | mph(kph) | 6.0 (9.6) | 5.6 (9.0) |
| | | | 15%, loaded | mph(kph) | 4.2 (6.7) | 2.8 (4.5) |
| | 26 | Lift speed, loaded/empty | Standard upright | fpm(ms) | 101/112 (.51/.57) | 89/111 (.45/.56) |
| | 28 | | Triple stage upright | fpm(ms) | 97/108 (.49/.55) | 90/105 (.45/.53) |
| | 29 | Lower speed,loaded/empty | Standard upright | fpm(ms) | 78.1/72.8 (.40/.37) | 78/92 (.39/.47) |
| | | Triple stage upright | fpm(ms) | 83/80 (.42/.41) | 80/80 (.41/.41) | |
| 30 | Drawbar pull, maximum | With load | lbs(N) | 5,250 (23350) | 5,000 (22240) | |
| | | Without load | lbs(N) | 2,380 (10580) | 3,125 (13900) | |
| 32 | Gradeability | At 1 mph (1.6 kph) with load | % | 24.2 | 16.5 | |
| | | Maximum with/without load | % | 27.1 (15.4) | 20.1 (18.0) | |
| Weights ¹ | 34 | Service weight | | lbs(kg) | 12,921 (5861) | 14,852 (6737) |
| | 35 | Axle loading | With load, front | lbs(kg) | 18,429 (8359) | 22,431 (10175) |
| | 36 | | With load, rear | lbs(kg) | 2,492 (1130) | 2,421 (1098) |
| | 37 | | Without load, front | lbs(kg) | 5,084 (2306) | 6,504 (2950) |
| | 38 | | Without load, rear | lbs(kg) | 7,837 (3555) | 8,348 (3787) |
| Chassis | 39 | Tires | Number, front/rear | | 2 / 2 | 2 / 2 |
| | 40 | | Size, front | in | 22 x 9 x 16 | 22 x 12 x 16 |
| | | | Size, rear | in | 18 x 6 x 12.12 | 22 x 7 x 16 |
| | 41 | Wheelbase | | in(mm) | 61.8 (1570) | 70.5 (1790) |
| | 42 | Track | Front/rear | in(mm) | 41.8/44.0 (1062/1118) | 43.8/43.0 (1113/1093) |
| | 44 | Ground clearance | Minimum/at center of wheelbase | in(mm) | 3.8/6.1 (97/155) | 3.8/6.1 (96/155) |
| | 46 | Service brake | Type | | Power assist disc | Power assist disc |
| | 47 | Parking brake | Actuation | | Foot applied | Foot applied |
| | Steering | Type | | Hydrostatic | Hydrostatic | |
| Drive Line | 49 | Engine | Manufacturer/model | | GM / Vortec 4300LT | GM / Vortec 4300LT |
| | 51 | | Rated output ⁴ | HP/kW@rpm | 93 / 69 @ 2400 | 93 / 69 @ 2400 |
| | | | Torque | Lb-ft/Nm@rpm | 235 / 318 @ 2000 | 235 / 318 @ 2000 |
| | 52 | | Speed, max governed | rpm | 2,650 | 2,650 |
| | 53 | | Cylinders/displacement | cu. In.-liters | 6 / 262 - 4.3 | 6 / 262 - 4.3 |
| 54 | Transmission | Manufacturer/type, speeds F/R | | Clark Powershift 1/1 | Clark Powershift 1/1 | |
| | 57 | Hydraulic pressure | For attachments | PSI/Bar | Adjustable | Adjustable |
| | 58 | Sound level | Avg. at operator's ear per ISO | dB(A) | 81 | 81 |

³ Optional reduced height overhead guard 83.1 in. (2110 mm) is available from factory only.
⁴ Engines rated per SAE J1349.

Notes:
¹ Weights and performance information are given on trucks with 122 (3073 mm), 116 (2945 mm) or 112 (2845) Standard uprights.
² For triple stage upright add 0.8 in. (20 mm).

| | | | | | | |
|---------------------------------------|----------------------------------|-------------------------------|--|--------------------------------|------------------------------------|-----|
| General Information | 1 | Manufacturer | | Clark | | |
| | 2 | Model | Manufacturer's designation | CGC 55 | | |
| | 3 | Load capacity | | lbs(kg) | 12,000 (5500) | |
| | 4 | Load center | Fork face to load CG | in(mm) | 24 (600) | |
| | 5 | Drive unit | Type | | LPG | |
| | 6 | Operator type | | | Rider counterbalanced | |
| | 7 | Tire type | | | Cushion | |
| | 8 | Wheels (x=driven) | Front/rear | | 2 x / 2 | |
| Basic Dimensions^{1,2} | 9 | Upright ^{1,2} | Maximum fork height, full capacity | in(mm) | 180 (4570) | |
| | 10 | | Lift height (preferred triple upright) | in(mm) | 169 (4288) | |
| | 11 | | Free lift ¹ | in(mm) | 6.9 (175) | |
| | 12 | Upright tilt | Back/forward (see tilt specifications) | degrees | 8 / 9 | |
| | 14 | Fork | Std. Fork size (TxWxL)/Class | in(mm) | 2.25 x 6 x 48 (57 x 152 x 1220)/IV | |
| | 15 | Overall dimensions | Length to fork face ² | in(mm) | 107.9 (2741) | |
| | 16 | | Width over drive axle | in(mm) | 54.8 (1392) | |
| | 17 | | Height, upright lowered ¹ | in(mm) | 90.0 (2281) | |
| | 18 | | Height, upright extended w/ load backrest ¹ | in(mm) | 160 (4065) | |
| | 18 | | Height, overhead guard ³ | in(mm) | 87.2 (2215) | |
| | 19 | Turning radius | Outside | in(mm) | 99.9 (2537) | |
| | 20 | Load center distance | Center of drive axle to fork face ² | in(mm) | 18.4 (467) | |
| | 22 | Right angle stack aisle | Add load length and clearance ² | in(mm) | 118.3 (3005) | |
| | Performance^{1,3} | 23 | Stability | According to ANSI/B56.1 | | Yes |
| 24 | | Speed | Travel speed, max w/load | mph(kph) | 11.7 (18.8) | |
| 25 | | Speed on grade, loaded | Travel speed, max w/o load | mph(kph) | 12.2 (19.6) | |
| | | | 5%, loaded | mph(kph) | 6.5 (10.4) | |
| | | | 10%, loaded | mph(kph) | 4.8 (7.7) | |
| | | | 15%, loaded | mph(kph) | 1.8 (2.9) | |
| 26 | | Lift speed, loaded/empty | Standard upright | fpm(ms) | 76.1/111 (.39/.56) | |
| 28 | | | Triple stage upright | fpm(ms) | 82/103 (.42/.52) | |
| 29 | | Lower speed, loaded/empty | Standard upright | fpm(ms) | 77/89 (.39/.45) | |
| | | | Triple stage upright | fpm(ms) | 75/78 (.38/.40) | |
| 30 | | Drawbar pull, maximum | With load | lbs(N) | 4,750 (21130) | |
| | | | Without load | lbs(N) | 3,205 (14255) | |
| 32 | Gradeability | At 1 mph (1.6 kph) with load | % | 15.4 | | |
| | | Maximum with/without load | % | 18.2 / 16.1 | | |
| Weights¹ | 34 | Service weight | | lbs(kg) | 16,881 (7657) | |
| | 35 | Axle loading | With load, front | lbs(kg) | 25,942 (11767) | |
| | 36 | | With load, rear | lbs(kg) | 2,939 (1333) | |
| | 37 | | Without load, front | lbs(kg) | 6,720 (3048) | |
| | 38 | | Without load, rear | lbs(kg) | 10,161 (4609) | |
| Chassis | 39 | Tires | Number, front/rear | | 2 / 2 | |
| | 40 | | Size, front | in | 22 x 12 x 16 | |
| | | | Size, rear | in | 22 x 7 x 16 | |
| | | | Wheelbase | in(mm) | 70.5 (1790) | |
| | 42 | Track | Front/rear | in(mm) | 43.8/43.0 (1113/1093) | |
| | 44 | Ground clearance | Minimum/at center of wheelbase | in(mm) | 3.8/6.1 (96/155) | |
| | 46 | Service brake | Type | | Power assist disc | |
| | 47 | Parking brake | Actuation | | Foot applied | |
| | Steering | Type | | Hydrostatic | | |
| Drive Line | 49 | Engine | Manufacturer/model | | GM / Vortec 4300LT | |
| | 51 | | Rated output ⁴ | HP/kW@rpm | 93 / 69 @ 2400 | |
| | | | Torque | Lb-ft/Nm@rpm | 235 / 318 @ 2000 | |
| | | | Speed, max governed | rpm | 2,650 | |
| | 53 | | Cylinders/displacement | cu. In.-liters | 6 / 262 - 4.3 | |
| 54 | Transmission | Manufacturer/type, speeds F/R | | Clark Powershift 1/1 | | |
| 57 | Hydraulic pressure | For attachments | PSI/Bar | Adjustable | | |
| | | 58 | Sound level | Avg. at operator's ear per ISO | dB(A) | 81 |

Notes: 1 Weights and performance information are given on trucks with 122 in. (3073 mm), 116 in. (2945 mm) or 112 in. (2845 mm) Standard uprights. 2 For triple stage upright add 0.8 in. (20 mm). 3 Optional reduced height overhead guard 83.1 in. (2110 mm) is available from factory only. 4 Engines rated per SAE J1349.

CLARK CGC40 SERIES cushion tire trucks are designed for use in manufacturing, building materials and paper handling, cargo and distribution where durability and responsiveness are required. Available with LPG fueled engines, these trucks provide high levels of operator comfort, low noise, reliability, and ease of service. Clark electric shift transmissions are standard.

Operator Control & Comfort

Genesis™ Series trucks feature a rubber isolated operator cell that provides a quiet, comfortable and spacious environment for operators of all sizes. The large floor area is free of obstructions and is covered with a permanent rubber mat. Large open steps and grab handles assist entry and exit from both sides. Two-pedal inch-brake system has low-height, short travel pedals. Left pedal is for inch and brake operation; right pedal is for brakes only. Left foot actuated parking brake.

Cowl mounted hydraulic control levers with soft touch knobs. Left hand, finger-tip operated directional control is electrically actuated; direction reversals are hydraulically cushioned. Equipped with a legendary Clark safety seat with shoulder restraints, adjustable and fold-down back rest, molded bolsters for comfort and support, six inches (150 mm) fore/aft adjustment, a retractable seat belt and an operator manual in the seat pocket. Tilt steering column provides 38° of adjustment; thick-section wheel is easily operated with one hand.

The instrument panel includes indicator lights for alternator charge, engine oil pressure, low LPG fuel, check engine light, transmission oil temperature, seat belt warning and park brake reminder. A five-digit hour meter and analog engine coolant temperature gauge are also provided.

LPG Engine

Equipped with an improved GM Vortec model 4300LT, 4.3L, V6 engine with hardened intake and exhaust valves and seats, a dynamic balancer system for reduced vibration, serpentine accessory belt drive and an EPA compliant LPG fuel system with diagnostics. An automatic engine shutdown system continuously monitors engine oil pressure, engine coolant temperature and transmission oil temperature. The tank mounting bracket accommodates 43.5 lb (19.7 kg) LPG tanks.

Engine Accessories/Capacities

Trucks are 12-volt negative ground. Starters are equipped with heavy-duty clutch and anti-restart system. Alternators have 65 amp output and incorporate internal regulation. Maintenance free batteries are rated at 420 CCA at 0°F (-18°C). Cyclopac air cleaners are used with high air intake, automatic dirt ejectors, and air restriction indicators. Supplemental safety element (optional) can be added without other changes. Engine oil is cooled by a heat exchanger located in the truck radiator.

Cooling system capacity is 15 qts. (15.8 L) and crankcase capacity is 5.5 qts. (5.2 L).

Service Access

Clamshell hood gives full access for inspection and service. Single piece floor panel is removable without tools. Filters are easily serviced and located to prevent spillage. An electronic panel on the front cowl provides easy access to relays and automotive blade-type fuses.

Transaxle

Clark H200ES single-speed, full reversing, powershift transaxle is an integral assembly of transmission, differential, and drive axles providing long life and high durability. A two-speed transaxle is optional. Solenoid actuated, hydraulic dampened shift control and

mechanical inching provide excellent modulation for precise control. Axle assemblies are enclosed with final reduction at the wheel hub. Inboard brakes benefit by torque multiplication which increases responsiveness. They are also protected from contamination for extended life. Externally mounted charge pump and parking brake assemblies are proven reliable and are easily accessed. Heavy-duty cooling system incorporates an independent oil-to-air transaxle oil cooler. Transmission test ports, neutral start switch and shift controls are located on the transmission control cover for simplified access and service. Full-flow transmission spin-on oil filter and sump screen are easily serviced.

Brakes

Hydraulically actuated disc-type brakes are power assisted. The disc brakes operate on the axle pinion shaft where brake torque is multiplied for responsive operation. Their enclosed location protects against contamination. Brake and inching operation with left pedal, braking only with right pedal. A left parking brake pedal actuates the transmission mounted service brake. The cable is easily adjusted from within the operator compartment.

Hydraulics

Gear type, direct drive pump provides fluid for hydraulic functions, steering and brake power assist. Priority-demand steering system conserves energy by supplying hydraulic fluid on demand-only basis. Hydraulic tank is integral with truck frame, in-tank return line filter is quickly changed without spill. A quick-connect pressure port on the pump enables convenient pressure checks. All pressure fittings utilize O-ring type face seals. Sump tank capacity is 19.4 gal. (73 L).

Steering

Fully hydrostatic power steering with variable ratio control; steer response varies with rate of hand wheel movement for improved control. A compact axle beam with an integral double acting steer cylinder. Spindle assemblies incorporate king pins with tapered roller bearings to provide a rugged, yet easily serviced assembly. Rubber isolation mounts supporting the axle absorb shock and reduce noise. Grease fittings extend linkage and bearing life.

Upright

High visibility standard and triple stage uprights of heavy C-channel outer rails and full I-section inner and intermediate rails. A wide range of lift heights is available. All-roller operation of upright rails and carriage rollers are canted to accept both normal and side thrust loads. The ITA Class III and IV carriages employ six main rollers with two inner and two outer thrust rollers to absorb off-center loading. Load backrests are designed for optimal visibility. Heavy pin-type mounts support the upright on the drive axle assembly. Simplified roller access improves serviceability. Hydraulic counterbalance valve prevents improper tilt cylinder operation, integral flow limiting valves prevent rapid carriage descent in the event of a line failure, and a lowering control valve regulates lowering speeds.

Additional Features

A single auxiliary valve and two headlights mounted on the overhead guard are standard equipment. The auxiliary hydraulic flow can be easily adjusted at the main valve to match the flow requirements of different attachments. With a one-piece hood and quickly removable floorplate, all routine maintenance checkpoints are readily accessible. The operator cell is designed for operator comfort and productivity. The Operator Manual is permanently attached inside the rear pocket of the comfortable safety seat. Color is high visibility Clark Green with non-glare matte black trim and white wheels. Tow pin in the counterweight is standard.

North America CMHC
Worldwide Headquarters
700 Enterprise Drive
Lexington, KY 40510
866-252-5275
www.clarkmhc.com

CGC40/50/55 Specification Sheet
59-894-0495 Printed in USA CClrev0305

your authorized CLARK dealer is:

| |
|--|
| |
|--|